

# COLOR FORCE II - 72

641-3000 REV A

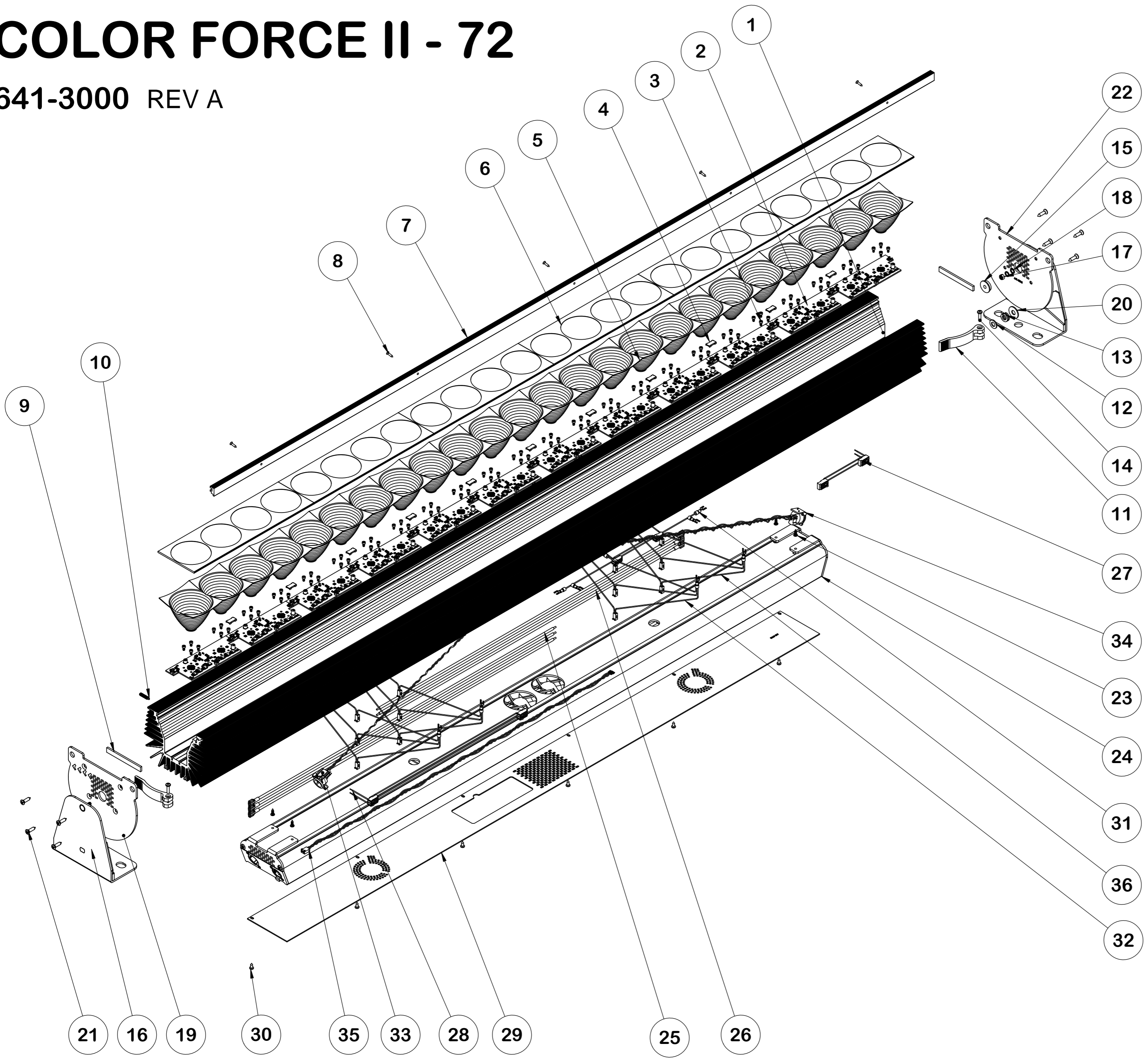

ITEM NO.	PART NUMBER	DESCRIPTION	QTY.
1	641-0585	EXTRUSION CF II MAIN BLACK ANODIZED	1
2	641-0105	PCB COMPLETE ENGINE CFII	12
3	430-1406-0	SCREW M3 X 6 SHCS BLK	96
4	900-2174	HIROSE BRIDGE (FLOATING PLUG) 3PIN	11
5	641-0320	REFLECTOR, CFII	24
6	641-0210	LENS CF II ASYMETRIC	6
7	641-0590	EXTRUSION CLAMP MACHINED BLACK ANODIZED	1
8	429-6110-0	SCREW SELF TAP FH PLPS BLK ST2.9x9.5 RoHS	5
9	900-0663	GASKET NEOPRENE 1/8x3/8 PSA	2
10	900-0407	PLUNGER SPRING STUBBY #10-32UNFx0.468 BLACK	2
11	622-0012	LEVER QUICK RELEASE	2
12	480-2518-1	WASHER FLAT M8 TYPE M	2
13	480-2914-4	WASHER DOUBLE SPRING M8	2
14	440-1216-0	SCREW M4x16 PH PLPS BLK	2
15	900-0655	BEARING F626ZZ 6mm W/FLANGE	2
16	622-0029	FOOT PLATE CF CFII BLK	2
17	450-3305-0	HEX NUT M5, NYLOCK BLK	2
18	326-2138-1	FLAT WASHER, 0.260" ID Ni	4
19	641-0014	END PLATE CFII LEFT BLK	1
20	480-2112-1	FLAT WASHER, M8 TYPE L ZPL	2
21	450-6719-0	SCREW SELF TAP RAISED CS PLPS BLK ST4.8x19	8
22	641-0015	END PLATE RIGHT BLK, CFII	1
23	306-1235-1	SCREW #6 PH PHILIPS ZINC 7/16" LENGTH	4
24	641-0535	BACKSHELL SUB-ASSEMBLY	1
25	641-0400	POWERCON TRUE 1 POWER IN TO FILTER PCB	1
26	641-0410	POWERCON TRUE 1 POWER OUT FROM FILTER PCB	1
27	641-0421	ITW 0.156 FILTER PCB TO PSU 1-2	1
28	641-0422	ITW 0.156 FILTER PCB TO PSU 3-4	1
29	641-0110	CLOSING PLATE w/ Q logo CFII 72 BLK	1
30	435-6295-0	SCREW SELF TAP PH PLPS BLK ST3.5x9.5 RoHS	6
31	641-0440	AUXILIARY POWER AND COMMON NEGATIVE	1
32	641-0442	PSU TO ENGINES 4-6/7-9	2
33	641-0450	XLR-5 INPUT TO CTRL PCB	1
34	641-0460	XLR-5 OUTPUT FROM CTRL PCB	1
35	641-0470	DATA TO 1ST ENGINE FROM CTRL PCB	1
36	641-0441	PSU TO ENGINES 1-3/10-12	2

# COLOR FORCE II - 72

641-0535

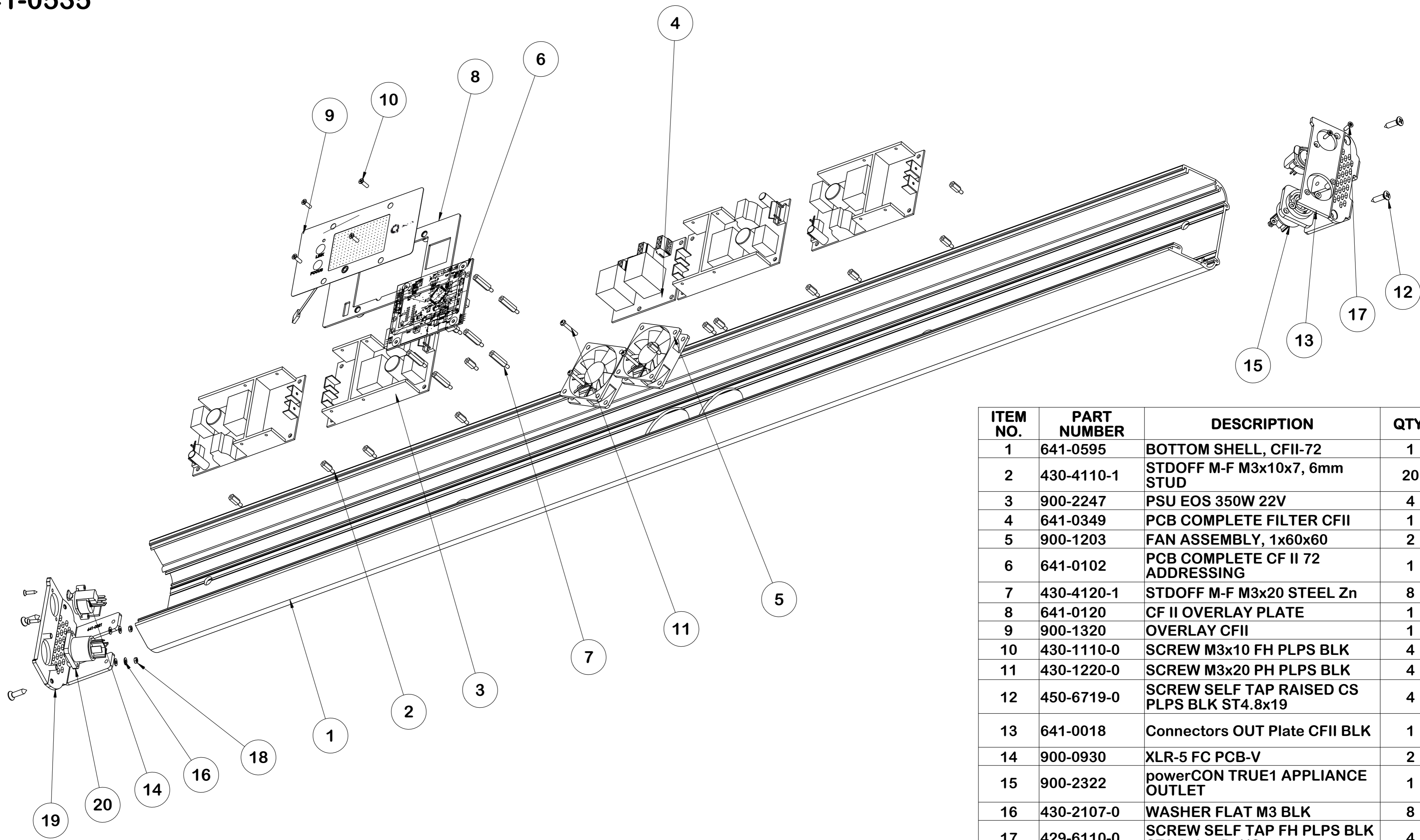

ITEM NO.	PART NUMBER	DESCRIPTION	QTY.
1	641-0595	BOTTOM SHELL, CFII-72	1
2	430-4110-1	STDOFF M-F M3x10x7, 6mm STUD	20
3	900-2247	PSU EOS 350W 22V	4
4	641-0349	PCB COMPLETE FILTER CFII	1
5	900-1203	FAN ASSEMBLY, 1x60x60	2
6	641-0102	PCB COMPLETE CF II 72 ADDRESSING	1
7	430-4120-1	STDOFF M-F M3x20 STEEL Zn	8
8	641-0120	CF II OVERLAY PLATE	1
9	900-1320	OVERLAY CFII	1
10	430-1110-0	SCREW M3x10 FH PLPS BLK	4
11	430-1220-0	SCREW M3x20 PH PLPS BLK	4
12	450-6719-0	SCREW SELF TAP RAISED CS PLPS BLK ST4.8x19	4
13	641-0018	Connectors OUT Plate CFII BLK	1
14	900-0930	XLR-5 FC PCB-V	2
15	900-2322	powerCON TRUE1 APPLIANCE OUTLET	1
16	430-2107-0	WASHER FLAT M3 BLK	8
17	429-6110-0	SCREW SELF TAP FH PLPS BLK ST2.9x9.5 RoHS	4
18	425-3102-1	NUT HEX M2.5, 5.5mm AF, Zn PLATED	4
19	641-0017	Connectors in Plate CFII BLK	1
20	900-2321	powerCON TRUE1 APPLIANCE INLET	1

# COLOR FORCE II- 72

641-0450

ITEM NO.	PART NUMBER	DESCRIPTION	QTY.
1	810-0011	22 AWG BLACK STRANDED TR64	1
2	900-2065	MOLEX 3 PIN HOUSING	1
3	810-0038	22 AWG RED STRANDED TR64	1
4	900-5115	SHRINK TUBE 1/8"IDx3/8" BLACK	2
5	900-0931	XLR-5 MC PCB-V (CC)	1
6	900-2078	MOLEX CRIMP TERMINAL ON REEL 22-30AWG	2

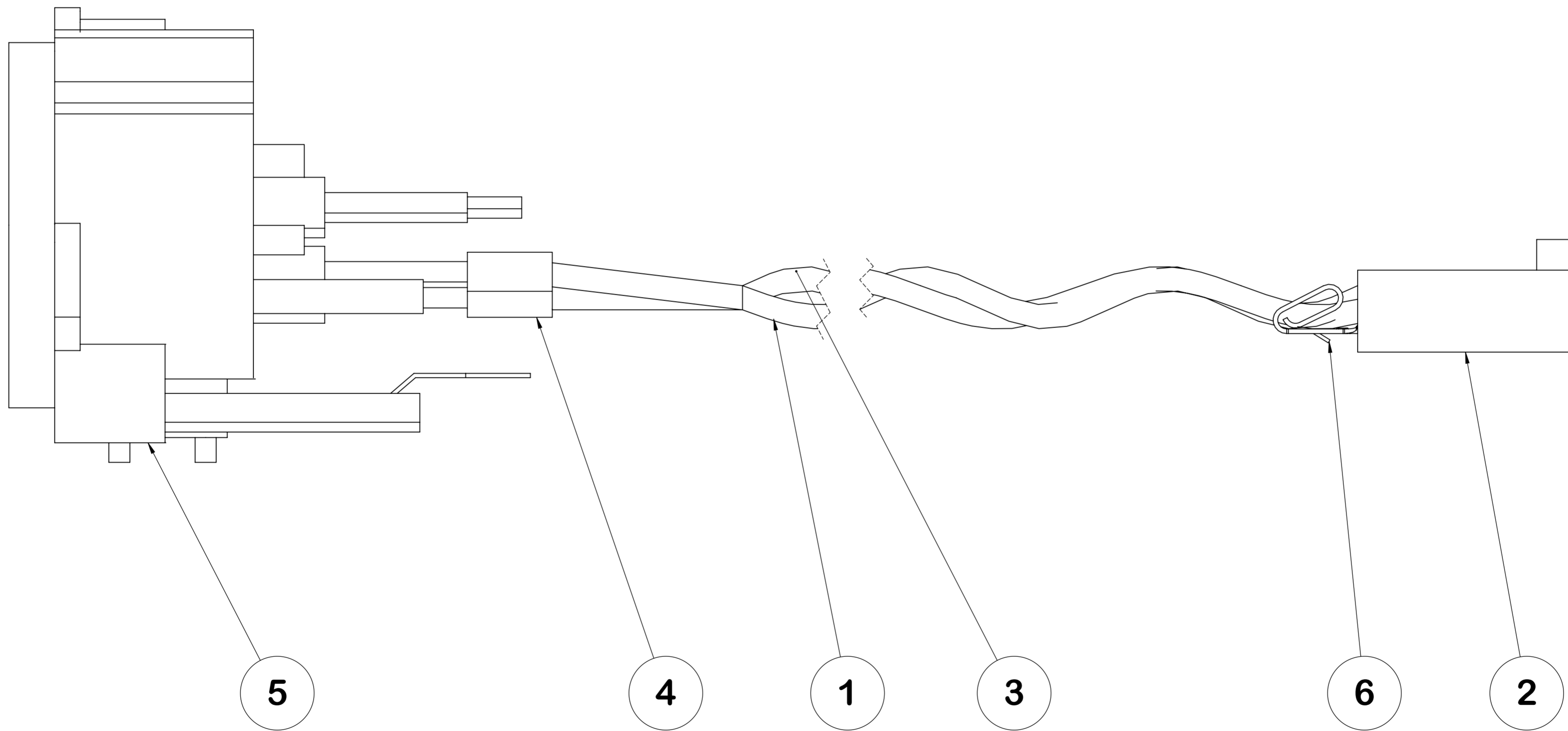

# COLOR FORCE II - 72

641-0460

ITEM NO.	PART NUMBER	DESCRIPTION	QTY.
1	810-0011	22 AWG BLACK STRANDED	1
2	810-0040	22 AWG GREEN STRANDED	1
3	900-2065	MOLEX 3 PIN HOUSING	1
4	810-0038	22 AWG RED STRANDED	1
5	900-0930	XLR-5 FC PCB-V	1
6	900-5115	SHRINK TUBE 1/8"IDx3/8" BLACK	3
7	900-2090	FERRITE TUBULAR BEAD	1
8	900-2078	MOLEX CRIMP TERMINAL ON REEL 22-30AWG	3

