

Chroma-Q™ Color Punch™

User Manual



Version 1.2 March 2008

PN: 620-0500

Disclaimer

The information contained herein is offered in good faith and is believed to be accurate. However, because conditions and methods of use of our products are beyond our control, this information should not be used in substitution for customer's tests to ensure that Chroma-Q products are safe, effective, and fully satisfactory for the intended end use. Suggestions of use shall not be taken as inducements to infringe any patent. Chroma-Q sole warranty is that the product will meet the sales specifications in effect at the time of shipment. Your exclusive remedy for breach of such warranty is limited to refund of purchase price or replacement of any product shown to be other than as warranted.

Chroma-Q reserves the right to change or make alteration to devices and their functionality without notice due to our on going research and development.

The Chroma-Q Color Punch has been designed specifically for the professional entertainment lighting industry. Regular maintenance should be performed to ensure that the products perform well in the entertainment environment.

If you experience any difficulties with any Chroma-Q products please contact your selling dealer. If your selling dealer is unable to help please contact support@chroma-q.com. If the selling dealer is unable to satisfy your servicing needs, please contact the following, for full factory service:

Outside North America:

Tel: +44 (0)1494 446000
Fax: +44 (0)1494 461024
support@chroma-q.com

North America:

Tel: 416-255-9494
Fax: 416-255-3514
support@chroma-q.com

For further information please visit the Chroma-Q website at www.chroma-q.com.

Chroma-Q is a trademark, for more information on this visit www.chroma-q.com/trademarks.

The rights and ownership of all trademarks are recognised.

Table of Contents

1. Product Overview	3
2. Operation	3
2.1 Unpacking the unit	3
2.2 Control and power cables	4
2.3 Mounting the unit	4
2.4 Operating the unit	4
2.5 Modes of operation	5
2.6 DMX Mapping	7
2.7 Pre-programmed looks	8
2.8 Technical specifications	8
2.9 Maintenance	8
2.10 Accessories	8
3. Drawings	9
3.1 Outside dimensions	9

1. Product overview

The Chroma-Q Color Punch lighting fixture is designed specifically for professional entertainment lighting. Its design is suitable for a wide range of lighting effects, including blinders footlights, side fills, truss toners, interior architectural and exterior lighting applications.

Each Color Punch fixture features 36 high power LED's which produce an exceptionally bright 1250 hot lumen output. With RGB control the fixture provides vibrant colours across the spectrum. A 22 degree lens gives a smooth and even wash across the beam.

Designed to be intelligent inside and out the Color Punch features a choice of stand-alone or DMX control for maximum versatility.

The products tough machined aluminium & high impact plastic casing is designed to thrive in all indoor and outdoor environments. Convection cooled, no fans mean completely silent operation.

The Color Punch has a built in power supply. The unit can be controlled though ANSI E1.11 USITT DMX 512-A.

2. Operation

- 2.1 Unpacking the unit
- 2.2 Control and power cables
- 2.3 Mounting the unit
- 2.4 Operating the unit
- 2.5 Modes of operation
- 2.6 DMX mapping
- 2.7 Pre-programmed looks
- 2.8 Technical specifications
- 2.9 Maintenance
- 2.10 Accessories

2.1 Unpacking the unit

The Color Punch package includes 1 x Color Punch fixture, 1 x yoke, 2 x M10 x 16 knobs.

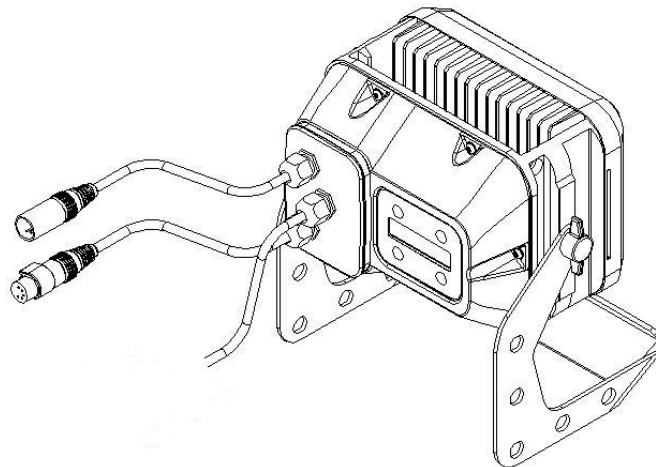

2.2 Control and power cables

The Color Punch is supplied with a 1m training power lead. Connection for control is via two trailing leads of XLR5 pin cable. The XLR 5-pin cables are wired pin to pin in the format shown in the table below. The chassis are ground bonded.

XLR 5-pin cable:

Pin #	Function	Minimum Cable size
1	Ground (-ve)	Screen
2	Control data minus (-)	0.35mm ² (22 AWG)
3	Control data plus (+)	0.35mm ² (22 AWG)
4	Spare data minus	0.35mm ² (22 AWG)
5	Spare data plus	0.35mm ² (22 AWG)

Power Cable:

International Colour Code	North American Colour Code	Connections	
Green and Yellow	Green	Earth (E)	Ground (Green)
Blue	White	Neutral (N)	Neutral (Silver)
Brown	Black	Live (L)	Hot (Gold)

Important Notice: The use of an opto-splitter for DMX signal distribution is highly recommended when several fixture units are not plugged into the same power source.

2.3 Mounting the unit

The Color Punch is supplied with a detachable yoke for a single fixture which can be used for floor mounting, direct wall mounting and truss mounting.

Note:

- For the M10 nuts, ensure that the bolt is not too long to avoid damage
- Secure each fixture with a safety bond. Provision for a fixing hold is built into the yoke. There is a provision for a secondary fixing built into the unit also.

2.4 Operating the unit

The Color Punch is controlled via a built in addressable ANSI E1.11 USITT DMX 512-A power supply. Control functions are accessed through the LCD display at the rear of the fixture with 4 push buttons.

Push button operation:

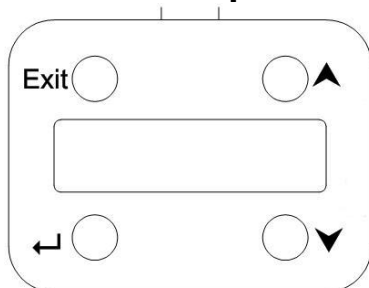

Control	Function
Exit	Back to previous Menu
Up Arrow	Increases (+) the mode level or value
Down Arrow	Decreases (-) the mode level or value
Back Arrow	Stores the Menu choice

Display operation:

Power-Up Display

On power-up the display shows the software version V### and the DMX address and the mode the Color Punch is in.

Display Mode

The LCD is backlit when you access the menus. This will turn off when left undisturbed for 5 seconds.

Default Settings:

'Factory' default settings

Reset

Press the UP or DOWN button until you get to 'Reset to Default' then press Enter. Then press the UP arrow to select YES and hold the Enter button for 2-3 seconds. This will reset the unit back to its 'Factory' Default.

2.5 Modes of operation

The Color Punch can be controlled via DMX or can be used in a standalone mode. You can also Master and Slave mode to connect Color Punches together and keep them in sync when in standalone mode.

a. Control menu

Use the wheel to scroll through the control menu positions:

→ Home / DMX Address

1 To set the DMX start address of the Color Punch, press Enter, press the UP/DOWN arrow to adjust DMX start address, press Enter for 2 seconds to save.

→ Control Mode

2 The Color Punch can be set to operate in various DMX controlled or standalone modes.

Mode 1 (3ch) – RGB

Mode 2 (5ch) – FX HSI

Mode 3 (5ch) – StRGBI

Mode 4 – Standalone Master (set the unit to be Master or Slave)

Mode 5 – Demo (Color Punch runs through a 'factory' set demo sequence)

Mode 6 – DMX Look Select (uses one DMX channel to recall saved looks or chases)

→ When DMX is Lost

3 If DMX is not detected various output options can be selected: press Enter, press the UP button to the required selection, and press Enter for 2 seconds to save.

Off – snap to off

Hold – hold the last valid DMX state

FX 1-99 – snap to the **FX** of your Choice

Look 1-20 – snap to the **Look** of your choice

Chase 1-10 – snap to the **Chase** of your Choice

There are 99 pre-built FX's in Color Punch. These are not editable.

→ Look Store

4 The Color Punch has 20 internal preset Looks for standalone operation, these come pre-programmed (see section 2.7). To replay a Look, press UP or DOWN and scroll through the Looks.

Note: DMX has priority over internal Looks.

Looks can be recorded to the internal flash memory by users and will be preserved on power down. However, looks will be returned to default setting if menu 8 reset is performed. There are two ways to record a look:

Simple, with DMX console.

Using a console set the look via DMX, scroll to Look Store and press enter, scroll to desired look and press Enter. Press enter again for 2 seconds to save Look.

Advanced, standalone.

Scroll to Look Store and press Enter, scroll to desired Look and press Enter to access

the memory data. The data is presented to you with the attribute on the right followed by the DMX value on the left. Depending on what mode you are in the attribute may change. Pressing the UP or DOWN arrow will select the attribute. This should be flashing to show that you are about to change that channel. To edit the channel level, press Enter to toggle to the number and use the UP or DOWN arrow to adjust the level (shown as 0-255). Press Enter to toggle back to the attribute. When the desired effect is created press Enter for 2 seconds to save Look.



Chase Store

5

The Color Punch allows you to use the Looks and to link these together in a Chase. Press Enter and scroll to desired Chase and press Enter. You are now presented with the Start Look.

Press Enter and then the UP or DOWN arrow to select the Start Look.

Press Enter to confirm and then press the UP arrow to move to the next option of the End Look.

Press Enter and then the UP or DOWN arrow to select the End Look in the chase.

Press Enter to confirm and the UP arrow to select the next option of Delay.

Press Enter and the UP or DOWN arrow to select the delay which is in seconds.

Press Enter to confirm and then the UP arrow to select the next option of XFade.

Press Enter to confirm and the UP arrow to set the Xfade. This is in seconds.

Press Enter to confirm.



DMX Levels

6

Press Enter to display the DMX levels that the Color Punch is receiving.



Information

7

Press enter to see the temperature of the unit, press DOWN to see the firmware version.



Reset to Default

8

Press the DOWN arrow to select Yes and hold enter for 2 seconds to reset all menu items to factory defaults:

DMX address = 001, Control Mode = 1 RGB, DMX Lost = Hold, Looks = default,

Chase = default.

b. DMX control modes

Mode 1: RGB (3ch)

This is the simplest of modes and is 3 channel control of Red, Green and Blue. Colour is mixed by adjusting the levels of the three primary colours. White is achieved with all channels at full.

Mode 2: HSI + FX (5ch)

This is controlled by 3 channels HSI (Hue, Saturation and Intensity) and 2 channels for effects. It gives 2 colour channels for hue and saturation, 1 separate intensity channel, 1 channel for colour roll speed and 1 channel for colour range. A separate definable intensity channel is particularly useful when creating intensity chases or when the grand master is used. The Hue channel has 255 different colours available and the saturation channel specifies the saturation of that colour. The saturation channel is fully saturated at full. White is achieved with the intensity channel to full and the Hue and Saturation channel to zero.

Colour Roll Speed: 0% - Off; 100% - Fastest

Color Range: 0% - Full Spectrum; 67% - 1/3 Colour Spectrum

Mode 3: StRGBI (5ch)

This is controlled by 3 channels of RGB (Red, Green and Blue), 1 channel for Master Intensity and 1 channel for Intensity Effects.

The first channel sets intensity effects and speed:

0-24% Fade on/Fade off

25-49% Fade on/Snap off

50-74% Snap on/Fade off

75-100% Strobe

Mode 4: Stand-alone

You can set the Color Punch to work in standalone mode and link Color Punches together so that they all remain in sync. If you set one unit to Master then the DMX will be regenerated and sent onto all the Slaves. This only works when you are in the When DMX is Lost option and have selected FX.

- F00-09 10 speeds full color roll
- F10-19 10 speeds cold color roll
- F20-29 10 speeds warm color roll
- F30-39 10 speeds magenta color roll
- F40-44 Blue (5 levels of saturation)
- F45-49 Cyan (5 levels of saturation)
- F50-54 Green (5 levels of saturation)
- F55-59 Yellow (5 levels of saturation)
- F60-64 Red (5 levels of saturation)
- F65-69 Magenta (5 levels of saturation)
- F70-79 10 fixed white colours: 2600K, 3200K, 3600K, 4100K, 5000K, 5600K, 6500K, 7000K, 7500K, 8000K
- F80-84 5 speeds fade on/fade off
- F85-89 5 speeds fade on/snap off
- F90-94 5 speeds snap on/fade off
- F95-99 5 speeds strobe

Color selection of intensity effects 'c00 to c29' is accessed when value is between F80-F99
To access the colour exit out of When DMX is Lost and press the down arrow. This will take you back to the FX #80-99 Color menu. You can then change the color of the Intensity FX

Mode 5: Demo

This is a pre-programmed sequence of the following (5 Seconds for each interval):

Start with 3 solid colours: Cyan, Yellow and Magenta;

Full colour roll;

Cold colour roll;

Warm colour roll;

Fade on/Fade off

Fade on/Snap off

Medium Strobe

Fast Strobe

Mode 6: DMX Look Select (1ch)

In this mode you have control of the Look store and Chase store with 1 channel of DMX.

2.6 DMX Mapping

These are the modes that are controlled via DMX.

Color Punch V001	Mode 1 RGB	Mode 2 FX HSI	Mode 3 StRGBI	Mode 6 DMX Look select
Channel 1	Red	Colour Roll	Strobe	20 - Looks Select 10 - Chase Select
Channel 2	Green	Colour Range	Red	
Channel 3	Blue	Hue	Green	
Channel 4		Saturation	Blue	
Channel 5		Intensity	Intensity	

2.7 Pre-Programmed Looks

These are the pre-programmed looks that are set as default. You can write over these in look store. To get back to these use the Reset to Defaults menu.

Look 1	Blackout	Look 11	Fast pastel roll
Look 2	White	Look 12	Slow rainbow roll
Look 3	Red	Look 13	Medium rainbow roll
Look 4	Yellow	Look 14	Fast rainbow roll
Look 5	Green	Look 15	32k White
Look 6	Cyan	Look 16	56k White
Look 7	Blue	Look 17	Red-Blue roll
Look 8	Magenta	Look 18	Blue-Green roll
Look 9	Slow pastel roll	Look 19	Cyan-Magenta roll
Look 10	Medium pastel roll	Look 20	Magenta-Yellow roll

2.8 Technical specifications

Dimensions:	212.7mm x 152.8mm x 179.1mm 8.37" x 6.02" x 7.05"
Weight:	3.56kg / 7.72lbs
DMX protocol:	ANSI E1.11 USITT DMX 512-A
Working Voltage:	90 – 240V AC
Power consumption:	81W
Connectors:	XLR5 in/thru.
Body material:	Aluminum extrusion
Body color:	Black anodised
European approvals:	Pending
North American approvals:	Pending



2.9 Maintenance

With care, the Color Punch fixture will require little maintenance. If the unit is used mainly in a stage environment then we recommend that the unit be periodically cleaned of dust and cracked oil residue. When used in an external environment make sure that the unit is clean and free from moisture around the power input and the data input and output.

2.10 Accessories

TBC

4. Drawings
4.1 Outside dimensions

