

Chroma-Q™ Color Web™ PSU320

User Manual



Version 1.0 July 2007

Disclaimer

The information contained herein is offered in good faith and is believed to be accurate. However, because conditions and methods of use of our products are beyond our control, this information should not be used in substitution for customer's tests to ensure that Chroma-Q products are safe, effective, and fully satisfactory for the intended end use. Suggestions of use shall not be taken as inducements to infringe any patent. Chroma-Q sole warranty is that the product will meet the sales specifications in effect at the time of shipment. Your exclusive remedy for breach of such warranty is limited to refund of purchase price or replacement of any product shown to be other than as warranted.

Chroma-Q reserves the right to change or make alteration to devices and their functionality without notice due to our on going research and development.

The Chroma-Q PSU320 has been designed specifically for the professional entertainment lighting industry. Regular maintenance should be performed to ensure that the products perform well in the entertainment environment.

If you experience any difficulties with any Chroma-Q products please contact your selling dealer. If your selling dealer is unable to help please contact support@chroma-q.com. If the selling dealer is unable to satisfy your servicing needs, please contact the following, for full factory service:

Outside North America:

Tel: +44 (0)1494 446000
Fax: +44 (0)1494 461024
support@chroma-q.com

North America:

Tel: 416-255-9494
Fax: 416-255-3514
support@chroma-q.com

For further information please visit the Chroma-Q website at www.chroma-q.com.

Chroma-Q is a trademark, for more information on this visit www.chroma-q.com/trademarks.

The rights and ownership of all trademarks are recognised.

Table of Contents

1. Product Overview	3
2. Operation	3
2.1 Unpacking the unit	3
2.2 Control and power cables	3
2.3 Mounting the unit	4
2.4 Connecting to Color Web	4
2.5 Web Layout	5
2.6 Addressing	5
3. Additional equipment	6
4. Technical specifications	7

1. Product overview

PSU320 is an integrated power controller for Color Web. Due to the robust design and truss mounting capability this product is well suited for temporary and permanent installations. Due to its high channel count the PSU320 has an integrated Ethernet port eliminating the need for DMX.

Ten outputs are provided; each output can drive a total of 32 pixels. Integrated into the design is an Ethernet switch allowing PSU320's to be daisy chained reducing the cabling required.

2. Operation

- 2.1 Unpacking the unit
- 2.2 Control and power cables
- 2.3 Mounting the unit
- 2.4 Connecting to Color Web
- 2.5 Web Layout
- 2.6 Addressing

2.1 Unpacking the unit

The Chroma-Q PSU320 package comes with the following items.

- Chroma-Q PSU320 Unit
- Power Supply Cord
- User manual

Note: The packing material protects the unit during shipping. Further copies of this manual can be downloaded from the website – www.chroma-q.com

2.2 Control and power cables

The Chroma-Q PSU320 is designed to control Color Web. For how these connect together then see section 2.4 on connecting the web.

Comms

The Chroma-Q PSU320 has an internal Ethernet switch module along with two RJ45 connections that enable it to be connected to further Chroma-Q PSU320's in a daisy chain configuration. Either port can be used to connect the controller. We recommend that you daisy chain no more than 4 PSU320's in one run. You should also make sure that you are using standard CAT5e patch cable.

Output Wiring

Each Chroma-Q PSU320 output is a 25pin multiway connector.

Connector Pin	Function
A,E,J,N,T	+V (Red)
B,F,K,P,U	Data (Green)
C,G,L,R,V	Clock (Yellow)
D,H,M,S,W	GND (Black)

Each output of the PSU320 is capable of powering/controlling 32 pixels through each of the ten outputs. This could be either

- Two Color Web 250 panels
- ½ Color Web 125 panel

For how these connect together then please see section 2.4 on connecting the web.

Indicators

Data (Green) Indicates that the data is being received for that universe.

Power (Red) Indicates good power and normal operation.

Comms (Yellow) Indicates that Art-Net communication packets have been received.

Test Switch

The Chroma-Q PSU320 has a test switch function that enables the unit to be tested without the controller. When pressed the PSU320 will sequence through its test routine, turn all internal LEDs on and ensure the fan is running.

Rotary Switch

Each output from the Chroma-Q PSU320 requires a full universe of DMX from the controller. Selecting the required universe and sub-net can be done using the rotary switches or through Art-Net Control.

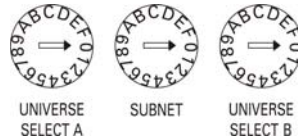

When selecting your universe the first 10 are numeric and then you have letters representing the next 6 universes. So A=10 B=11 C=12 etc etc. Then after 16 if you need to address a PSU320 to 17 you change to subnet 1 and use universe select 0 on the dial.

Earthing

The following table summarises the internal earth interconnection and isolation

Circuit	Description	
Chassis	Bonded to Earth-Ground.	
Ethernet (RJ45)	Type:	Isolated.
	Data:	Connects to internal isolated circuit. No connection to Earth-Ground.
	Shell:	The connector shell is connected to chassis.
Internal Logic Ground	Connects to Earth-Ground.	

2.3 Mounting the unit

- Flying or overhead mounting of equipment shall be undertaken by qualified staff. The staff shall be capable of undertaking a risk assessment.
- Each PSU320 provides safety wire points that must be used.
- Safety should be your prime concern. If in any doubt seek professional advice.

2.4 Connecting to Color Web

The PSU320 can be used with Color Web 125 & Color Web 250. Below are diagrams that show how these connect together to the PSU.

Color Web 125

The PSU320 will connect to 5 panels of the color web 125. Each output from the PSU feeds half of a panel / 32 pixels

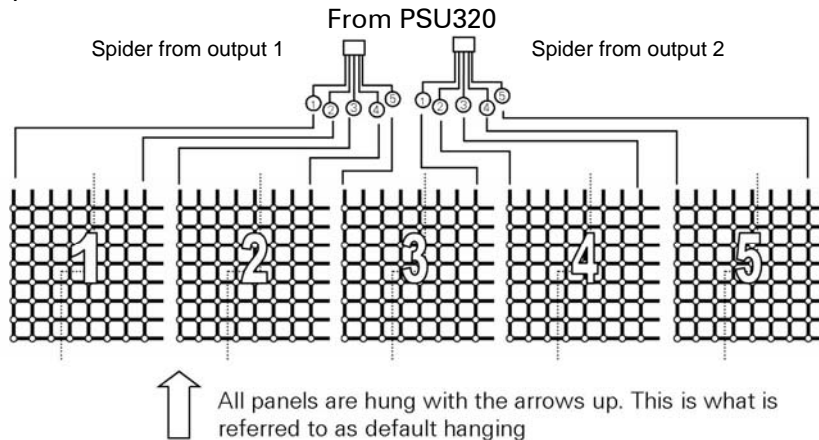

Color Web 250

The PSU320 will connect to 20 panels of the color web 250. Each output from the PSU feeds two panels/ 32 pixels.

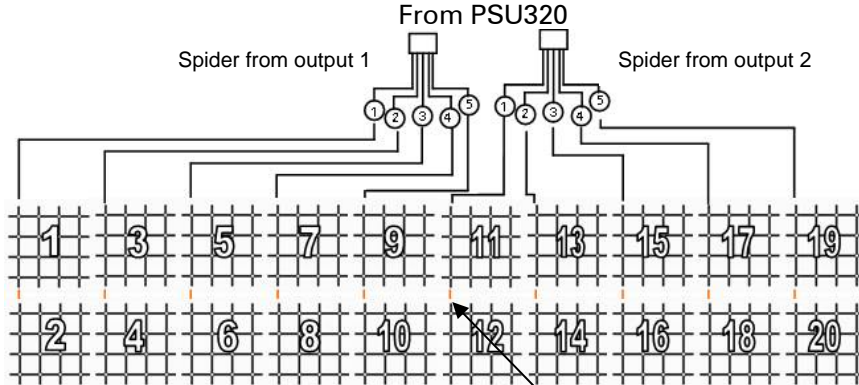

All Panels are hung with the arrows pointing up. This is what is referred to as default hanging.
Two Panels connect here. Output of top panel into input of bottom panel

2.5 Web layout

This is the default layout of the Color Web 250 and 125. Nodes are addressed in order and each node takes 3 channels of DMX, Red, Green and Blue. This is how the string of nodes are wired into the panels. This is viewed from the front with arrows facing up.

Color Web 250

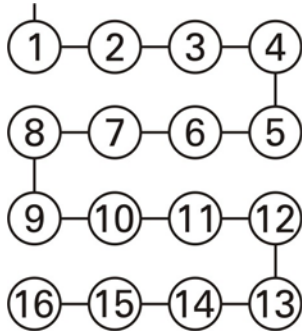

Color Web 125

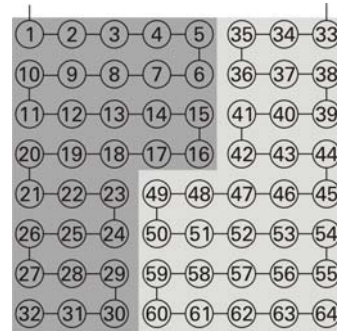

2.6 Addressing

Each Chroma-Q PSU320 will control up to 320 RGB pixels. Each pixel has 3 DMX channels. Red, Green and Blue. This is a total of 480 DMX control channels per Chroma-Q PSU320's output.

There are two outputs from each PSU320 giving you a total of 960 DMX channels per unit. Each output is factory set to DMX address 001. You select the universe for each output via the rotary switches on top of the unit.

The simplest way to treat the PSU320 when addressing is to look at it as two separate power supplies in one. So each output has 5 ways and its own universe select. Each output on the spider plugs into an input on the web and the patching is sequential across each output.

The tables below show how each panel is typically patched.

***Each Output is on a different universe that is set via the rotary dials on the top of the unit.**

Color Web 250

Panel Number	DMX Address	Spider Output A	Spider Output B
1/11	1	1	1
2/12	49	Linked to Panel 1	Linked to Panel 11
3/13	97	2	2
4/14	145	Linked to Panel 2	Linked to Panel 12
5/15	193	3	3
6/16	241	Linked to Panel 3	Linked to Panel 13
7/17	289	4	4
8/18	337	Linked to Panel 4	Linked to Panel 14
9/19	385	5	5
10/20	433	Linked to Panel 5	Linked to Panel 15

Color Web 125			
Panel Number	DMX Address	Spider Output 1	Spider Output 2
1 Left	1	1	
1 Right	97	2	
2 Left	193	3	
2 Right	289	4	
3 Left	385	5	
3 Right	1		1
4 Left	97		2
4 Right	193		3
5 Left	289		4
5 Right	385		5

3. Additional equipment

Color Web Spiders CHCWSPY

Each Color Web PSU 10-DMX has a connector on the front for a Spider. The Spider plugs into the PSU and has 5 x 2m leads coming from it with 4 pin connectors at the ends. Each output is marked with white plastic rings, one thru five.



Color Web 250 CHCW250

Each Color Web 250 panel is made up of one string of 16 LED nodes. This starts in the top left and snakes down to the bottom left. Each LED Node has its own DMX address. This is assigned depending on which output from the PSU it is plugged into.



Color Web 125 CHCW125

Each Color Web 125 panel is made up of two strings of 32 LED nodes. This starts in the top left and top right and snakes down. Each LED Node has its own DMX address. This is assigned depending on which output from the PSU it is plugged into.

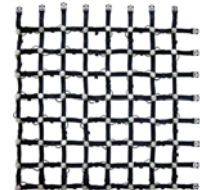

Color Web Extension Cables CHCWCE#

Extension cables are available in 1m, 2m, 3m, 4m, 5m and 6m lengths. These are used to extend cable runs from the spider to the panels.



Multicore CHCWME5/CHCWME10

There are 2 multicore lengths, 5m and 10m. These go between the power supply and the spider. The maximum length between PSU and spider is 10m.



IP65 End Caps CHCWCECAP

Whilst the Web is IP65 rated, the connectors that are not in use are exposed. This cap will protect the exposed connectors to an IP65 rating.



Color Web Fly Adapters

Fly Adapters are used to attach the Panels to a hanging point, normally a pipe or piece of truss. These have two ways of hanging. If you click the connector into the top this will hang the Web with a 576mm drop from the bar to the first pixel. If you click it into the bottom connector then this will lift it 125mm allowing you to offset the Web and double hang. So you then put the adapters at 125mm intervals and every other one is lifted. You can use these up to a 10m drop before you need to use a secondary fixing on the back of the Web



4. Technical specifications

Dimensions:	218 x 186 x 110mm (8.58 x 7.32 x 4.33 in)
Weight:	2.5kg / 5.51 lb
Mains connection:	IEC
IP rating:	IP20 indoor use (not suitable for outdoor use. Use extension cables CHCWME5/CHCWME10 from PSU320 to Color Web)
Power consumption:	200W
Input Voltage:	90-264V AC
Input frequency:	47-440Hz
Current - inrush:	40A-115V / 80A-230V
Output Voltage:	9VDC
Output current:	2 x 10A
Duty Cycle:	80%
Control connection:	2 x RJ45 (Ethercon)
Mating multi-way connector:	Trident ringlock plug TR1823PMS1NB

Chroma-Q Color Web (CHCW250 and CHCW125)

Dimensions:		1m x 1m 3.3 ft x 3.3 ft
Weight:	CHCW250: CHCW125:	800g / 1.76lbs 1.8kg / 4.06lbs
Connector:	CHCW250: CHCW125:	Mini 4-pin in and out 2 x Mini 4-pin in and out
Colour:		Black
Led cells:	CHCW250: CHCW125:	16 x Osram RGB 64 x Osram RGB
Cell pitch:	CHCW250: CHCW125:	250mm / 10" 125mm / 5"
Lamp life:		25,000 hours estimated average
IP rating:		IP65 (when end caps used)
Max drop:		10m drop with 4:1 safety ratio
Beam angle:		120°

