

# Chroma-Q™ Twin FX DMX

User Manual



Version 1.2 December 2006

PN: 149-0500

## **Disclaimer**

The information contained herein is offered in good faith and is believed to be accurate. However, because conditions and methods of use of our products are beyond our control, this information should not be used in substitution for customer's tests to ensure that Chroma-Q products are safe, effective, and fully satisfactory for the intended end use. Suggestions of use shall not be taken as inducements to infringe any patent. Chroma-Q sole warranty is that the product will meet the sales specifications in effect at the time of shipment. Your exclusive remedy for breach of such warranty is limited to refund of purchase price or replacement of any product shown to be other than as warranted.

Chroma-Q reserves the right to change or make alteration to devices and their functionality without notice due to our on going research and development.

The Chroma-Q Twin DMX gobo rotator has been designed specifically for the professional entertainment lighting industry. Regular maintenance should be performed to ensure that the products perform well in the entertainment environment.

If you experience any difficulties with any Chroma-Q products please contact your selling dealer. If your selling dealer is unable to help please contact [support@chroma-q.com](mailto:support@chroma-q.com). If the selling dealer is unable to satisfy your servicing needs, please contact the following, for full factory service:

**Outside North America:**

Tel: +44 (0)1494 446000  
Fax: +44 (0)1494 461024  
[support@chroma-q.com](mailto:support@chroma-q.com)

**North America:**

Tel: 416-255-9494  
Fax: 416-255-3514  
[support@chroma-q.com](mailto:support@chroma-q.com)

For further information please visit the Chroma-Q website at [www.chroma-q.com](http://www.chroma-q.com).

Chroma-Q is a trademark, for more information on this visit [www.chroma-q.com/trademarks](http://www.chroma-q.com/trademarks).

The rights and ownership of all trademarks are recognised.

# Table of Contents

<b>1. Product Overview</b>	<b>3</b>
<b>2. Operation</b>	<b>3</b>
2.1 Control and power cables	3
2.2 Installation of the gobos	4
2.3 Operating the unit	5
2.4 Mode of operation (inc. DMX addressing)	6
2.5 Mounting the unit on a lighting fixture	8
2.6 Troubleshooting	9
2.7 Technical overview	10
2.8 Technical specifications	10
<b>3. Drawings</b>	<b>11</b>
3.1 Outside dimensions	11

## 1. Product overview

The Chroma-Q Twin DMX (Mk2) is a full-featured DMX controlled indexing gobo rotator, designed to accept any combination of two B sized metal or glass gobos (refer to technical specification section for full details). It features an advanced built-in effects system, allowing the user to create stunning kinetic effects.

The unit is designed to fit in the gobo gate or iris slot of ETC Source4, Altman Shakespeare, Strand SL, & Selecon Pacific ellipsoidal fixtures. It is equipped with a diagnostic section on the LED display showing power, data signal & level presence.

The Chroma-Q Twin DMX (Mk2) is designed to operate either on the ANSI E1.1 USITT DMX512-A protocol or in stand-alone mode (without a dedicated controller). The DMX serial data system allows for the individual addressing of multiple units on one data cabling system. The unit utilises one or two DMX channels depending on the mode of operation. The unit is addressed by using the three push button switches & LED display located on the side of the unit. These switches are also used to select mode of operation, effects, speeds, etc.

In the DMX mode, the unit is supplied power & control signals by means of two 4-pin XLR style connectors on the top of the unit, allowing multiple units to be daisy-chained into the same line of cabling. Patching the output from the last unit back into the power supply will terminate the DMX for each chain line & ensure even power voltage across all the units in that chain.

When operating in the stand-alone mode the Chroma-Q Twin DMX (Mk2) only requires a 24VDC supply to operate.

**Note:** The quantity of Chroma-Q Twin DMX (Mk2) used & maximum cable length per power supply output is dependant upon the size of PSU/splitterbox used (see later in this manual for details).

## 2. Operation

- 2.1 Control & power cables
- 2.2 Installation of the gobos
- 2.3 Operating the unit
- 2.4 Mode of operation (inc. DMX addressing)
- 2.5 Mounting the unit on a lighting fixture.
- 2.6 Troubleshooting
- 2.7 Technical overview
- 2.8 Technical specifications

### 2.1 Control and power cables

The Chroma-Q Twin DMX (Mk2) utilises an XLR 4-pin cable system. In DMX mode, this is used to supply power & data transfer. Pins 1 & 4 are supply 24VDC power. Pins 2 & 3 supply ANSI E1.1 USITT DMX512-A control protocol, with a ground/drain wire to the connector shell.

For use in stand-alone mode the unit only requires a suitable 24VDC connected to pins 1 & 4.

Damage will occur if power connections short to data or ground/shield connections. When assembling XLR 4-pin cables, heat shrink should be used on each individual pin to prevent short circuits (see diagram below).

**Note:** It is very important to ensure that the drain wire from the cable shield is connected to both the XLR connector cases.

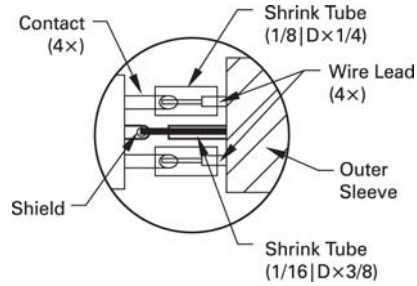

Detail of connector wiring

The correct wiring between male & female connectors is 'one to one'.

Pin #	Pin #	Minimum Cable size
1	Ground (-ve)	2.50mm <sup>2</sup> (14 AWG)
2	Control data minus (-)	0.35mm <sup>2</sup> (22 AWG)
3	Control data plus (+)	0.35mm <sup>2</sup> (22 AWG)
4	24V DC (+ve)	2.50mm <sup>2</sup> (14 AWG)
Chassis	Cable shield/drain wire	0.25mm <sup>2</sup> (24 AWG)

**Note:** Cable length should not exceed more than 60m/200' with return line.

### Connections

Correct connection of the units to the power supply will decrease the chances of units malfunctioning due to cabling problems. Please follow these basic rules:

- Use the correct & gauge type of cable & connectors.
- Keep cable runs as short as possible to reduce line loss.
- Always use a return cable for each run. This will ensure balanced DC power to all units that the line is correctly terminated & all units receive power if one link of the chain is faulty.

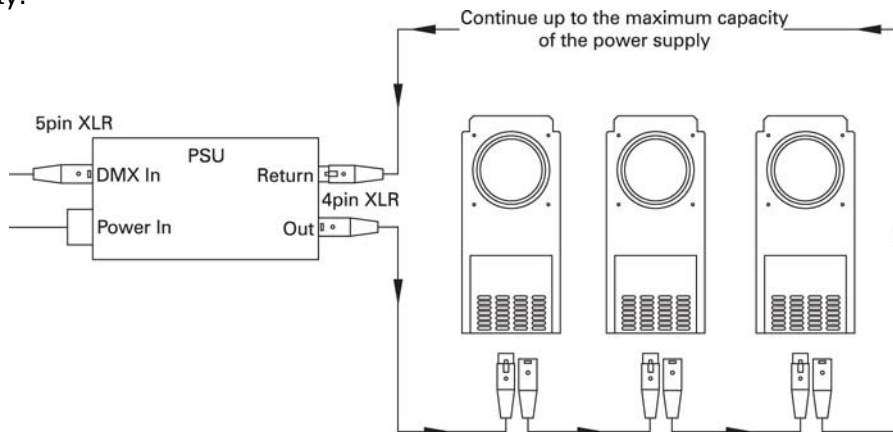

## 2.2 Installation of gobos

The unit consists of two counter-rotating gobo holders in the same axial plane. The rear gobo holder is equipped with magnetic sensor system, which allows repeatable indexing of this gobo holder (200 steps = 360°, 1 step = 1.8°).

The gobos are held firmly in place by sprung retaining rings. Both the gobo holders & rings are designed to hold both metal & glass patterns.

The retaining rings can be removed by placing a small tool in one of the grooves of the ring & then prying the end of the ring out of the holder.

When replacing the retaining rings, start by inserting one end of the ring into the holder & then work around pushing the rest of the ring into its slot in the holder. Check the rings are fully seated in their slots before operating the unit.

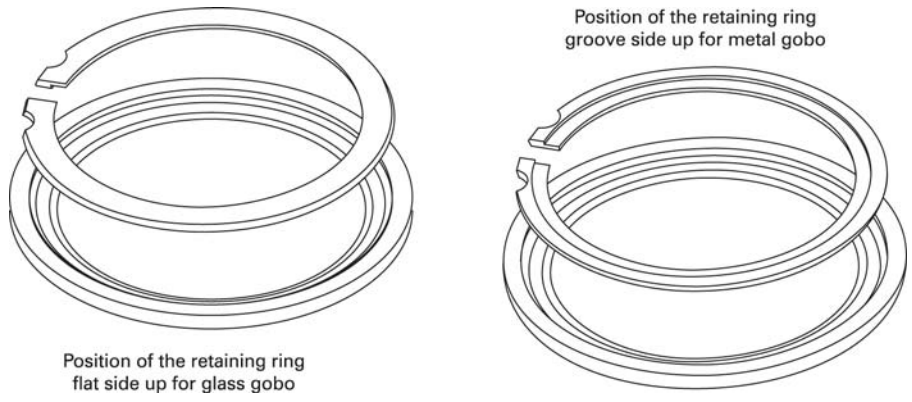

**Metal Gobos**

When installing metal gobos, the circular indentation in the retaining ring should be facing outwards.

**Glass gobos**

When installing glass gobos, the circular indentation in the retaining ring is used to accommodate the greater thickness of the glass gobo & therefore should be facing inwards.

**Note:** These notes are intended to help the user, however no responsibility will be accepted for any actions arising from there implementation.

- a) Due to the heat generated in the fixture, new metal gobos tend to warp when they are first used in a fixture. Although this is normal, it can potentially cause problems when two gobos are counter-rotating closely together. It is suggested that new gobos are pre-heated in the fixture before actual use of the unit. The gobo warpage can then be observed & corrected if necessary.
- b) If the units are used for different shows in repertory, it may be worth marking a line on the gobo & holder to show the zero position (alignment) of the gobo.
- c) If a gobo is made of very thin material, it may spin freely in the holder & therefore loose registration. A small spot of high temperature silicon rubber between the gobo & the retaining ring should hold it in place.
- d) When using etched glass gobos, the uncoated side of the gobo should always be nearest to the fixture light source.

**2.3 Operating the unit**

All the unit functions are accessed using the LED display & the three push-button switches on the rear panel.

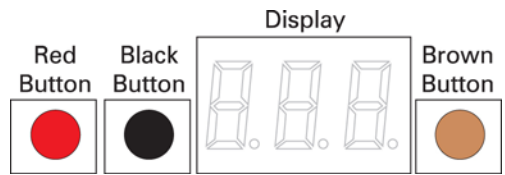

Control	Function
Red Button	Mode access and record
Black Button	Decreases (-) the mode level or value
Brown Button	Increases (+) the mode level or value
3 digit display	Displays mode, monitor or blank display

### Push button operation:

The red button is used to scroll through the different modes of operation. The brown or black buttons are used to select the level or value in that mode. If any mode or value is changed, the display will flash until the red button is pushed to save the change.

### Display operation:

#### Power-up display

On power-up, the display will show the DMX address mode.



#### Monitor display

If left undisturbed for 5-7 seconds, the display will revert to Monitor mode.

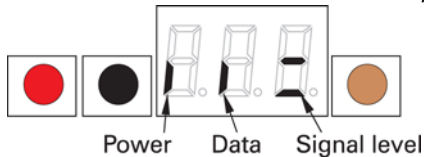

The first vertical bar indicates that there is power (24VDC).  
The second vertical bar indicates that there is data (DMX).  
The horizontal bars indicate the data (DMX) signal level.

#### Display flip

The display can be flipped through 180° by pressing & holding the red button, then pressing the black button.

#### Display blank

The display can be set to auto-blackout after short time. This is selected through the Display mode menu (see later in this section).

#### Reset

If the red button is held down & the brown button pressed for 2 seconds, the unit will reset to the Factory default settings. This feature is particularly useful when the units are used in many different configurations or shows.



## 2.4 Modes of operation

### DMX address or speed mode

In this mode the display will show either the current DMX address or the effects speed settings, depending on the Control mode settings. To alter the value, press the brown or black button once to step the value or hold down the buttons for fast adjustment. Press red to save the new setting.

**Note:** The display shows 'P\*\*' when showing effects sPeed

### Control mode

This mode is used to set the control mode of the unit. The unit operates in two DMX modes or 17 stand-alone modes without DMX control (see separate chart overleaf for further details). To alter the value, press the brown or black button once to step the value. Press red to save the new setting.

### Display mode (dP)

This mode is used to switch the default display On or Off. This feature can be used to blank the display when in normal use. However the display will re-activate when any button is pressed. Press the brown or black buttons once to switch between On (1) & Off (0) (the default is On). Press red to save the new setting.

#### Note:

- The red button is used to scroll through the different modes of operation, & the brown or black buttons are used to select the level or value in that mode.
- If any mode or value is changed the display will flash until the red button is pushed to save the change.
- When the red record button is pressed, the unit will save the change & these User defaults will take precedence on the next power cycle or remote reset.

- d) Resetting the unit will return all of the user settings to Factory defaults. Press & hold the red & brown buttons at the same time for 2 seconds to reset the unit.

Mode	Display	Display	'P' Speed	'P' Value
DMX1		Single channel DMX mode (see below)	N/A	N/A
DMX2		Dual channel DMX mode (see below)	N/A	N/A
Auto-Rotation		Gobo Rotation	Rotation speed Q (fast-slow) Rotation speed P (slow-fast)	P00-49 P50-99
Gobo Position		Gobo position 1 (0°)	These are used to check position, alignment etc. for the '3 gobo position change' effect	
		Gobo position 2 (120°)		
		Gobo position 3 (240°)		
Gobo Change		3 gobo position change (0°/120°/240°)	Step delay (≈ secs)	P00-99
Effects		▲▲ (0-full speed) ∪	▲ Rate (fast-slow)	P00-99
		'Clock Tick' ∪	Sweep size 2°-30° Sweep size (30°-2°)	P00-49 P50-00
		▲▲ ∪	▲▲ Rate (fast-slow)	P00-99
		Random Shimmer/Shake	Shake speed (slow-fast)	P00-99
		'Advancing Two-Step' 50° ∪ - 30° ∪	Step speed ∪ (fast-slow) Step speed ∪ (slow-fast)	P00-49 P50-99
		1 revolution ∪ + pause	Rotation speed ∪ (fast-slow) Rotation speed ∪ (slow-fast)	P00-49 P50-99
		1 rev ∪ + pause + 1 rev ∪	Rotation speed ∪ (fast-slow) Rotation speed ∪ (slow-fast)	P00-49 P50-99
		'Pendulum' (≈ ± 45° swing)	Swing speed (slow-fast)	P00-99
		'Pendulum' (≈ ± 90° swing)	Swing speed (slow-fast)	P00-99
		'Pendulum' (≈ ± 180° swing)	Swing speed (slow-fast)	P00-99
		Gobo Shimmer/Shake	Shake speed (slow-fast)	P00-99
		Gobo Shimmer/Shake -3s pause	Shake speed (slow-fast)	P00-99

### Single DMX Channel mode (CH1)

In this single channel mode, the unit acts solely as a gobo rotator, with the DMX value controlling the speed & direction of rotation.

DMX channel value	Movement
0%	= Stopped
1%(fast)-49%(slow)	= Forward rotation
50%(slow)-100%(fast)	= Reverse rotation

## Dual DMX Channel mode (CH2)

In the dual channel mode the unit is fully controllable by DMX, offering rotation, indexing, & a large number of motion effects. The second DMX channel value sets the effect type & the first DMX channel controls the variable function of that effect.

Effect selection channel 2	DMX ch 2 % value	Effect selection channel 1	DMX ch 1 % value
Indexing speed ⤴ (fast-slow)	0-24%	Indexing position (0°-360°)	1-100%
Indexing speed ⤴ (fast-slow)	25-49%	Indexing position (0°-360°)	1-100%
Gobo position 1 (0°)	50-53%	Movement speed (slow-fast)	1-100%
Gobo position 2 (120°)	54-57%	Movement speed (slow-fast)	1-100%
Gobo position 3 (240°)	58-61%	Movement speed (slow-fast)	1-100%
Gobo shimmer/shake	62-65%	Shake speed (slow-fast)	1-100%
Gobo shimmer/shake - 3s pause	66-69%	Shake speed (slow-fast)	1-100%
'Advancing Two-Step' 50° ⤴ - 30° ⤴	70-71%	Step speed (slow-fast)	1-100%
'Advancing Two-Step' 50° ⤴ - 30° ⤴	72-73%	Step speed (slow-fast)	1-100%
'Clock Tick' ⤴	74-75%	Sweep size (60°-2°)	1-100%
'Clock Tick' ⤴	76-77%	Sweep size (60°-2°)	1-100%
Random shimmer/shake	78-81%	Shake speed (slow-fast)	1-100%
1 revolution ⤴ + pause	82%	Pause length (long-short)	1-100%
1 revolution ⤴ + pause	83-84%	Pause length (long-short)	1-100%
1 rev ⤴ + pause + 1 rev ⤴	85-87%	Pause length (long-short)	1-100%
▲ (0-full speed) ⤴	88-89%	▲ Rate (fast-slow)	1-100%
▲ (0-full speed) ⤴	90%	▲ Rate (fast-slow)	1-100%
▲▲ ⤴	91-92%	▲▲ Rate (fast-slow)	1-100%
▲▲ ⤴	93%	▲▲ Rate (fast-slow)	1-100%
'Pendulum' (» ± 12° swing)	94%	Swing speed (slow-fast)	1-100%
'Pendulum' (» ± 23° swing)	95%	Swing speed (slow-fast)	1-100%
'Pendulum' (» ± 34° swing)	96%	Swing speed (slow-fast)	1-100%
'Pendulum' (» ± 45° swing)	97%	Swing speed (slow-fast)	1-100%
'Pendulum' (» ± 60° swing)	98%	Swing speed (slow-fast)	1-100%
'Pendulum' (» ± 75° swing)	99%	Swing speed (slow-fast)	1-100%
'Pendulum' (» ± 90° swing)	100%	Swing speed (slow-fast)	1-100%

### Legend

⤴	CW rotation	⤴	CCW rotation	▲	Accelerate	▲	Decelerate
---	-------------	---	--------------	---	------------	---	------------

## Default Settings

### Factory default settings

To reset the unit to the Factory default settings, press & hold the red & brown buttons for 2 seconds.

The Factory default settings put the unit in its safest operating mode.

Control mode = Single DMX

Display = On

Display flip = Standard

### User default settings

Following any adjustment of settings, pressing the red record button will save the adjusted settings as the new User defaults. The new User defaults will take precedence on the next power cycle. User defaults can be reset to the Factory defaults using the method detailed above.

## 2.5 Mounting the unit

The unit should be inserted in the gobo gate or iris slot of the lighting fixture with the control-box housing facing the front of the fixture. Ensure the rotator is correctly seated in the iris slot

before powering the lighting fixture (when correctly seated there should be no sideways movement of the unit).

The Chroma-Q Twin DMX (Mk2) is designed for mounting in an upright or side mounted position with the top control-box housing above, or at the side of, the fixture. Do not mount in an inverted position with the top control-box housing below the fixture.

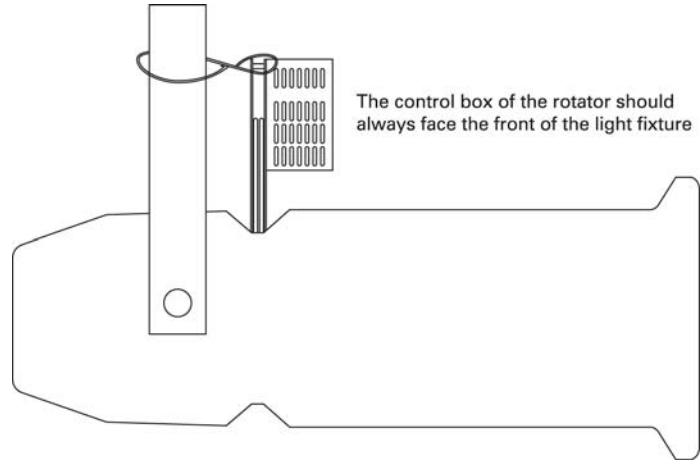

**Safety Wire**

The Chroma-Q Twin DMX (Mk2) should always be used with the safety wire. There is a hole provided in the chassis for the attachment of a safety wire.

**2.6 Troubleshooting**

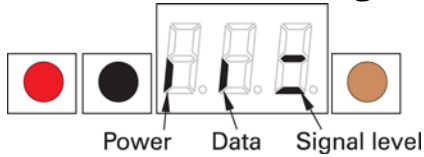

The first vertical bar indicates that there is power (24VDC).  
 The second vertical bar indicates that there is data (DMX).  
 The horizontal bars indicate the data (DMX) signal level.

**Note:** The signal level changes during normal operation of the unit & is present during stand-alone operation. 1st bar = 25%, 2nd bar = 50% & 3rd bar = 75%.

**Note:** A high percentage of problems are a direct result of poor cabling, corrupt DMX control signals, & lack of suitable signal termination.

Symptom	Possible Cause	Solution
Unit does not respond to DMX control, but DMX display indicator is on.	Unit set to wrong or different DMX address.	Check DMX address settings.
Unit does not respond to DMX, DMX display indicator is off.	Bad cable. No DMX at splitter/PSU	Check cable & DMX run from the console
Units run at different speeds.	Cable lengths are too long  No cable return line	Check the cable length & configuration. Ensure there is a cable return line in the system.
Units have dim display indicators & run slowly.	Overloading of chain or cable runs too long. PSU overloaded.	Check voltage levels on last unit, should not be below 20V DC.
Display indicators appear OK but does not move.	Mechanical (or electrical) failure in the unit.	Turn unit on & off. Return unit for repair

## 2.7 Technical overview

The electronics card consists of three key components: L298 motor driver, 75176 transceiver, & a processor. The 75176 transceiver operates in the receive configuration to convert serial protocol to a TTL level. All data relevant to the operation of the unit is stored onboard in 'flash' memory. The gobo rotation system employs an electro-magnetic system for accurate positioning of the gobo.

The majority of electronics problems are usually created by external factors such as shorted cables, etc. The 75176 transceivers are susceptible to damage if 24VDC is present on the DMX signal lines.

Troubleshooting is a process of elimination. First, rule out the other field factors (i.e. faulty cables or power sources). If an electronics problem is suspected try replacing the electronics card first. If accuracy problems should occur, & mechanical problems have been ruled out, clean & check the position sensor. For technical advice &/or parts, please contact your selling dealer or the offices listed in this manual.

## 2.8 Technical specifications

Dimensions:	264mm (l) × 119mm (w) × 70mm (d) 10.4" × 4.7" × 2.8"	
Weight:	1.15kg/2.5 lb	
Gobo media:	Metal or glass	
Gobo capacity:	Two 'B' size gobos per unit	
Gobo dimensions:	Outside dia	Thickness
'B' size metal	86mm/3.5"	0.2mm/0.008"
'B' size glass mono	79.4mm/3.125"	1.1mm/0.043"
'B' size glass multi	79.4mm/3.125"	2.3mm/0.009"
Cooling:	Convection (natural)	
DMX protocol:	ANSI E1.1 USITT DMX512-A	
DMX addressing:	Digitally, via 3 push buttons & LED display	
Working Voltage:	24VDC (+/- 10%)	
Power consumption:	0.6PU (see note below)	
Connectors:	XLR-4 (male) in & XLR-4 (female) through	
Body material:	Steel	
Body color:	Black high temperature paint (other colours available, P.O.A.)	
Mounting plate:	Integral mounting plate, designed for use in ETC Source4, Altman Shakespeare, Strand SL & Selecon Pacific fixtures	
Approvals:	EN 55103-1, EN 55103-2, IEC 60950, FCC Part 15 and ICES-003 Class A	

**Note:** To simplify the choice of power supply we use the "PU" (Power Unit) to calculate the load requirements of the Chroma-Q system. For example a PS-02 will supply up to 2 PU's, so you can plug-in 3 Chroma-Q Twin DMX (Mk2) Gobo Rotators ( $3 \times 0.6\text{PU} = 1.8\text{PU}$ ) into a PS-02.



### 3. Drawings

#### 3.1 Dimensions

