

Chroma-Q™ Universal

User Manual



Version 1.3 December 2006

PN: 111-0501

Disclaimer

The information contained herein is offered in good faith and is believed to be accurate. However, because conditions and methods of use of our products are beyond our control, this information should not be used in substitution for customer's tests to ensure that Chroma-Q products are safe, effective, and fully satisfactory for the intended end use. Suggestions of use shall not be taken as inducements to infringe any patent. Chroma-Q sole warranty is that the product will meet the sales specifications in effect at the time of shipment. Your exclusive remedy for breach of such warranty is limited to refund of purchase price or replacement of any product shown to be other than as warranted.

Chroma-Q reserves the right to change or make alteration to devices and their functionality without notice due to our on going research and development.

The Chroma-Q Universal has been designed specifically for the professional entertainment lighting industry. Regular maintenance should be performed to ensure that the products perform well in the entertainment environment.

If you experience any difficulties with any Chroma-Q products please contact your selling dealer. If your selling dealer is unable to help please contact support@chroma-q.com. If the selling dealer is unable to satisfy your servicing needs, please contact the following, for full factory service:

Outside North America:

Tel: +44 (0)1494 446000
Fax: +44 (0)1494 461024
support@chroma-q.com

North America:

Tel: 416-255-9494
Fax: 416-255-3514
support@chroma-q.com

For further information please visit the Chroma-Q website at www.chroma-q.com.

Chroma-Q is a trademark, for more information on this visit www.chroma-q.com/trademarks.

The rights and ownership of all trademarks are recognised.

Table of Contents

1. Product Overview	3
2. Operation	3
2.1 Control and power cables	3
2.2 Operating the unit	4
2.3 Modes of operation (inc. DMX addressing)	5
2.4 Gel loading	8
2.5 Mounting the unit	10
2.6 Troubleshooting	11
2.7 Technical overview	11
2.8 Technical specifications	12
3. Drawings	13
3.1 Outside dimensions of the unit	13
3.2 Gel dimensions	13
3.3 Examples of mounting bracket positions	14

1. Product overview

The Chroma-Q Universal is designed to give years of trouble free use, providing that it is regularly maintained & is used in accordance with the instructions detailed in this manual. If you should experience any problems that fall outside of the scope of this manual, please contact the selling dealer.

The Chroma-Q Universal is a scrolling colour changer designed to operate on the ANSI E1.11 USITT DMX 512-A protocol. This multiplexed serial data system allows for the individual addressing of multiple units on one data cabling system. The unit utilises one or two DMX channels depending on the mode of operation.

The unit is addressed by using the three push button switches & LED display on the rear panel. These switches are also used to select mode of operation, scrolling speed & cooling fan speed.

The Chroma-Q Universal is supplied power & control signals by means of two 4-pin XLR style connectors on the rear panel, allowing multiple units to be 'daisy-chained' into the same line of cabling. Patching the output from the last unit back into the power supply will terminate the DMX for each chain line & ensure even power voltage across all scrollers in that chain.

Note: The quantity of Chroma-Q Universal colour changers, & maximum cable length per power supply output is dependant upon the size of PSU/splitterbox used (see later in this manual for details).

The rear of the unit incorporates an integral universal mounting bracket, which allows the unit to be easily configured to fit on fixtures from 160-275mm / 6¼"-10¾" frame size.

The Chroma-Q Universal is equipped with two internal cooling fans & a diagnostic section on the LED display showing power, DMX signal & level presence.

2. Operation

- 2.1 Control and power cables
- 2.2 Operating the unit
- 2.3 Modes of operation (inc. DMX addressing)
- 2.4 Gel loading
- 2.5 Mounting the unit
- 2.6 Troubleshooting
- 2.7 Technical overview
- 2.8 Technical specifications

2.1 Control and power cables

The Chroma-Q Universal utilises an XLR 4-pin cable system. This is used for power & data transfer. Pins 2 & 3 are for ANSI E1.11 USITT DMX 512-A data. Pins 1 & 4 are for 24VDC power.

Damage will occur if power connections short to data or ground/shield connections.

When assembling XLR 4-pin cables, heat shrink should be used on each individual pin to prevent short circuits (see diagram below).

Note: It is very important to ensure that the drain wire from the cable shield is connected to both XLR connector cases.

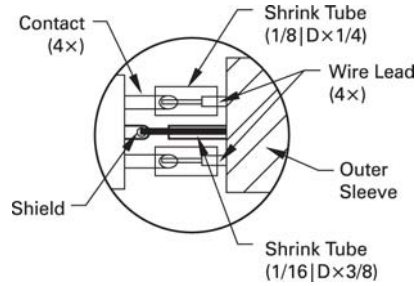

Detail of connector wiring

The correct wiring between male & female connectors is 'one to one'.

Pin #	Pin #	Minimum Cable size
1	Ground (-ve)	2.50mm ² (14 AWG)
2	Control data minus (-)	0.35mm ² (22 AWG)
3	Control data plus (+)	0.35mm ² (22 AWG)
4	24V DC (+ve)	2.50mm ² (14 AWG)
Chassis	Cable shield/drain wire	0.25mm ² (24 AWG)

Note: Cable length should not exceed more than 60m/200' with return line.

Connections

Correct connection of the units to the power supply will decrease the chances of units malfunctioning due to cabling problems. Please follow these basic rules.

- Use the correct type & gauge of cable & connectors.
- Keep cable runs as short as possible to reduce line loss.
- Always use a return cable for each run. This will ensure balanced DC power to all units, that the line is correctly terminated, & all units receive power if one link of the chain is faulty.

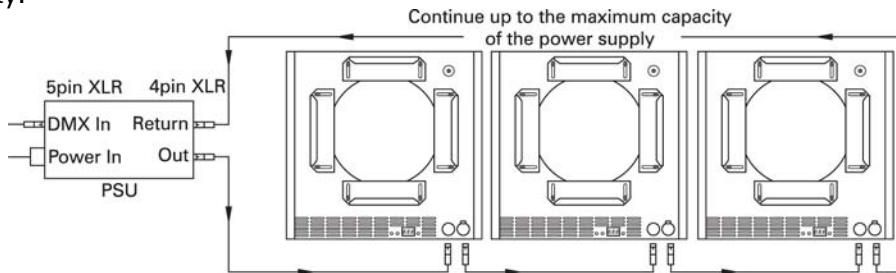

2.2 Operating the unit

All the unit functions are accessed using the LED display & the three push-button switches on the rear panel.

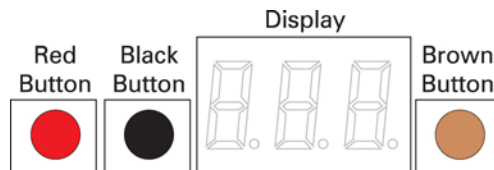

Control	Function
Red Button	Mode access and record
Black Button	Decreases (-) the mode level or value
Brown Button	Increases (+) the mode level or value
3 digit display	Displays mode, monitor or blank display

Push button operation:

The red button is used to scroll through the different modes of operation. The brown or black buttons are used to select the level or value in that mode. If any mode or value is changed, the display will flash until the red button is pushed to save the change.

Display operation:

Power-up display

On power-up, the unit will go through its self-calibration mode & the display will show the units software version.



After the self-calibration finishes, the display will show the DMX address.



Monitor display

If left undisturbed for 5-7 seconds, the display will revert to 'Monitor Mode'.

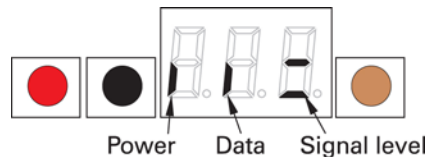

The first vertical bar indicates that there is power (24VDC) at the unit.
The second vertical bar indicates that there is data (DMX) at the unit.
The horizontal bars indicate the data (DMX) signal level at the unit.
(See also: 'Troubleshooting' section of this manual)

Display flip

The display can be flipped through 180° by pressing & holding the red button, then pressing the black button.

Display blank

The display can be set to auto-blackout after short time. This is selected through the Display mode menu (see later in this section).

Reset

If the red button is held down & the brown button pressed, the unit will reset to the factory default settings. This feature is particularly useful when the units are used in many different configurations or shows. The reset function is also available via DMX (see remote operation section of this manual).



2.3 Modes of operation

Note:

- The red button is used to scroll through the different modes of operation & the brown or black buttons are used to select the level or value in that mode.
- If any mode or value is changed the display will flash until the red button is pushed to save the change.
- When the red record button is pressed, the unit will save the change & these new User defaults will take precedence on the next power cycle or remote reset.
- The unit will not save any change made by remote operation after the next power cycle.
- Resetting the unit will return all of the user settings to factory defaults. Press & hold the red & brown buttons at the same time to reset the unit.

DMX addressing mode

This mode is used to set DMX data address of the unit. The unit uses one or two DMX channels depending which mode it is operating. The display shows the current DMX address (between 1-512).

To alter the value, press the brown or black button once to step the value; hold down the buttons for fast adjustment. Press red to save the new setting.

Fan speed mode (Fn)

Fan speed mode is used to set the gel cooling-fan speed of the unit. This feature can be used in environments where a lower noise level is required. The display shows the current gel cooling fan speed. There are four fan speeds, 1 is the slowest & 4 the fastest (the default is 4). To alter the value, press the brown or black button once to step the value; hold down the buttons for fast adjustment. Press red to save the new setting.

This feature is also available via DMX (see "Remote operation" section of this manual).

Note: reducing the fan speed may reduce the life of the gel string.

Gel saver mode (GL)

Gel-saver mode is used to switch the gel-saving mode on or off. This feature slowly moves the chosen gel frame back & forward slightly so that the heat build-up is dissipated over a larger area, extending the life of the gel string. Press the brown or black buttons once to switch between On (1) & Off (0) (the default is Off). Press red to save the new setting.

This feature is also available via DMX (see "Remote operation" section of this manual).

Speed mode (SP)

Speed mode is used to set the maximum scrolling speed of the unit. This feature allows the gel string to move at a higher speed for more rapid changes. Use of the high speed will generate more noise from the unit. Press the brown or black buttons once to switch between Standard (1) & Fast (2) (the default is Standard). Press red to save the new setting.

This feature is also available via DMX (see "Remote operation" section of this manual).

Display mode (dP)

This mode is used to switch the default display On or Off. This feature can be used to blank the display when in normal use. However the display will re-activate when any button is pressed. Press the brown or black buttons once to switch between On (1) & Off (0) (the default is On). Press red to save the new setting.

Remote operation mode (ro)

Remote operation mode is used to select between the 3 control modes. The use of these different modes greatly enhances the versatility of the unit by giving the user remote control of the most of the functions. Press the brown or black buttons to switch between the modes (the default is Mode 1). Press red to save the new setting.

Mode 1 =	Single channel DMX operation. The channel controls the colour selection.	
Mode 2 =	Dual channel DMX operation. The 1st channel controls the colour selection. The 2nd channel controls the fan speeds: 0-24% = Fn 4 (fast), 25-39% = Fn 3, 50-74% = Fn2, 75-100% = Fn 1 (slow)	
Mode 3 =	Dual channel DMX operation. The 1st channel controls the colour selection. The 2nd channel controls the units other functions.	
These functions initialise two seconds after the channel level entered.	Channel 2 level	Feature
	0-5%	= No feature
	6-15%	= Fan off
	16-25%	= Fan speed 1 (slowest)
	26-35%	= Fan speed 2
	36-45%	= Fan speed 3
	46-55%	= Fan speed 4 (fastest)
	56-65%	= Gel Saver off
	66-75%	= Gel Saver on
	76-85%	= Motor speed normal, see Speed mode (SP)
	86-95%	= Motor speed fast, see Speed mode (SP)
	96-100%	= Reset (reset to user defaults)

Default Settings:

User default settings

Each time the red record button is pressed, the unit will save that change & these User defaults will take precedence on the next power cycle or remote reset.

Factory default settings

If the unit is reset, using the red button (held down) & the brown button pressed, the unit will reset to the Factory default settings.

The Factory default settings put the unit in its safest operating mode.

Fan speed = 4 (fast)

Gel saver = 0 (off)









Gel speed = 1 (slow)

Display = 1 (on)

Remote operation = 1 (normal)

Display flip = standard

Summary of control functions

Operation or mode	Operation description	Actions required	Display
Power-Up	Software version - shown on the unit at power-up.	This shows the software version while the unit is self-calibrating, before displaying the 'Monitor Mode'.	
rESet	This will reset the unit to the default settings.	While holding down the red button, press the brown button.	
Power Assisted Loading (EZ Load)	Used to load a gel string into the unit.	Hold down the red button during power-up. Pressing the black button will advance the gel in that direction. Pressing the brown button will advance the gel in the opposite direction. Press both brown & black buttons, or cycle the power, to recalibrate.	
Modes (use the red button to scroll through these modes)			
DMX addressing mode	Used to set the units DMX addresses	The display shows DMX address (1-512). Press brown or black once to increment/decrement the value, hold down the brown or black for fast advance/retreat.	
Press red to save the new settings			
Fan speed mode	Used to set the fan speed of the unit	The display shows the current gel cooling fan speed. There are four fan speeds, 1 is the slowest, 4 is the fastest. Press brown or black once to increment/decrement the value	 
Press red to save the new settings			
'GeL Saver' mode	Switches on/off the gel saving mode	The display shows the current gel saver mode. Press brown or black once to switch between on (1) & off (0).	 
Press red to save the new settings			

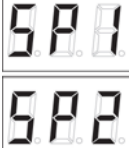
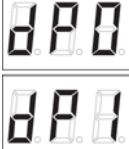
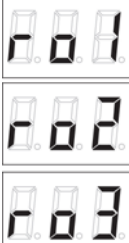
'SPeed' mode	Used to set the scrolling speed of the unit	The display shows the current gel scrolling speed. There are two scrolling speeds, 1 is the slowest & 2 is the fastest. Press black or brown once to increment/decrement the value.	
Press red to save the new settings			
'disPlay' mode	Switches on/off the display	Switches the display on or off. Display will re-activate when any button is pressed. Press brown or black to switch between on (1) & off (0).	
Press red to save the new settings			
'remote operation'	Mode 1 = single DMX channel operation. Mode 2 = Dual DMX channel operation (Colour/Fan speed). Mode 3 = Dual DMX channel operation (Colour/Function).	The display shows the current DMX mode of the unit. There are three DMX modes. Press brown or black to increment/decrement the mode setting.	
Press red to save the new settings			

2.4 Gel loading

Changing the gel string on the Chroma-Q Universal is not difficult, but it may take some time & practice to accomplish, if the user is not familiar with the unit.

There are two methods of loading gel strings on the Chroma-Q Universal, manually or using the power assisted loading method (EZ Load).

Note: It is suggested that new users of this product load the gel strings by the manual method until they become familiar with the units.

To change the gel string you will need:

- 1 x Gel string for a Chroma-Q Universal
- 1 x Roll of flat back adhesive tape 25mm / 1" wide ("Artists" tape)
- 1 x Phillips No.1 screwdriver

Preparation

- 1) Unplug the unit & remove it from the lighting fixture to which it is attached. Using the screwdriver, remove the four M3 x 4mm screws holding the front cover onto the unit & carefully remove the front cover.
- 2) Remove all pieces of the old gel string if necessary. This may involve unwinding the gel from the Take-Up Reels (TUR). Exercise caution to avoid damaging the gel transport mechanism.

Replacing the gel string (manual mode)

Note: See also the drawing section of this manual.

- 1) Place the unit on a flat surface with the motor/fan/electronics section on your right-hand side (assuming you are loading the gel string from the 'tail' end, reverse the position if starting with the 'leader' end of the string).
- 2) Using 25mm/1" long pieces of tape, attach the leading edge of the gel string to the plastic TUR at the top & bottom of the string, ensuring that the gel is centred on the TUR. Move the gel string to the side & attach the other side string to the TUR with tape (a black line has been scribed along the TUR to assist with this).

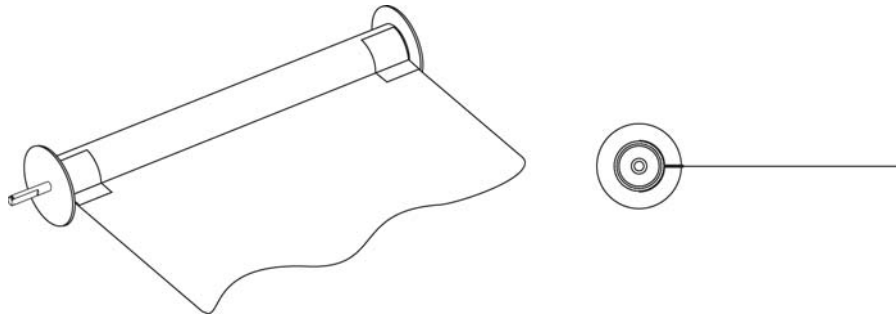

- 3) Manually turn the fixed gear of the shaft to slowly roll the gel string onto the TUR. Continue rolling the gel onto the TUR until the other end is reached.
- 4) Firmly holding the gear of the rear fixed shaft (to stop it moving), gently pull the gel tab towards you. This ensures that the gel is tightly rolled onto the TUR.
- 5) Rotate whole the unit so that the motor/fan/ electronics section on your left hand side. Place the gel beside TUR.
- 6) Use 25mm /1" pieces of tape to secure the gel to the TUR top & bottom, & on both sides (a black line has been scribed along the TUR to assist).
- 7) Manually roll some of the gel string onto the TUR to check it is seating itself correctly.

Completion & testing

- 1) Plug in the unit, & check that it goes through the initialisation sequence correctly. Check that the gel runs smoothly & does not bind up on the TUR's.
- 2) Unplug the unit, replace the front cover & secure with the M3 screws.
- 3) Run a test sequence to allow the gel string to 'bed' in. The unit does not have to be attached to a lighting fixture to perform this. It is recommended that run this sequence for a few minutes (or 3/4 times, end-to-end).

Replacing the gel string (EZ-Load)

Note: See the drawing section of this manual.

- 1) Follow steps 1+2 in the preparation section.
- 2) While pressing down the red push button, apply power to the unit.

The display will show the legend PAL



- 3) Using 25mm/1" long pieces of tape attach the leading edge of the gel string to the plastic TUR at the top & bottom of the string, ensuring that the gel is centred on the TUR. Move the gel string to the side & attach the other side string to the TUR with tape (a black line has been scribed along the TUR to assist with this).
- 4) Press the black push button to advance the gel string onto the TUR.
- 5) Continue this process until you see the other end of the gel string approaching.
- 6) Firmly holding the gear of the rear fixed shaft (to stop it moving), gently pull the gel tab towards you. This ensures that the gel is tightly rolled onto the TUR.
- 7) Use 25mm/1" pieces of tape to secure the gel to the TUR top & bottom, & on both sides (a black line has been scribed along the TUR to assist with this).
- 8) Press the brown push button to move the gel string back onto the TUR. Use the push buttons to move the gel to & fro, checking that the gel is sitting correctly on the TUR's.
- 9) Allow the unit to self-calibrate by pressing the brown & black buttons simultaneously or by cycling power to the unit.

Completion & testing

- 1) Plug in the unit & check that it goes through the initialisation sequence correctly. Check that the gel runs smoothly & does not bind up on the TUR's.

- 2) Unplug the unit, replace the front cover & secure with the M3 screws.
- 3) Run a test sequence to allow the gel string to 'bed' in. The unit does not have to be attached to a lighting fixture to perform this operation. It is recommended that run this sequence for a few minutes (or 3/4 times, end-to-end).

Note:

- a) For normal operation, the start of the gel string is on the left-side TUR & the end of the string on the right-side TUR, when viewed from the front of the unit.
- b) Do not power lights without powering up the unit first. The fans must be running in order to protect gels from premature failure.
- c) High fan speed is recommended on all lighting fixtures of 750 Watts & above.
- d) Use of a high quality IR filter on ellipsoidal lighting fixtures is strongly recommended, especially those with beam angles of less than 30 degrees.
- e) Poorly optimised lamps in some fixtures may result in premature gel failure.

2.5 Mounting the unit

Note: See drawing section of this manual.

The Chroma-Q Universal is designed for mounting in an upright position with the base of the unit below the fixture. Do not mount in an inverted position with the base of the unit above the fixture, as the rising heat from the fixture may cause the gel string damage.

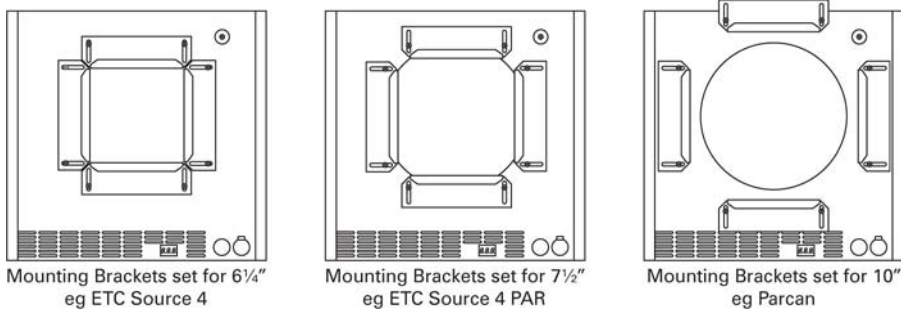

The rear of the unit incorporates an integral universal mounting system, which allows the unit to be easily configured to fit on fixtures from 158mm/6 1/4" to 275mm/10 3/4" frame size. This system consists of four brackets, held by eight screws, fixed to eight (of possible sixteen) mounting stand-off fixings.

To alter the mounting brackets, simply loosen the two screws on each bracket, move the bracket to the required position and re-tighten the screws. The brackets have a combination of letters & numbers stamped on them so that you can record the particular sizes you use. Some examples of these bracket positions are given below and in the drawing section of this manual:

Bracket Position	Standoff Position	Fixture
3	Inside	Source 4
A	Inside	Source 4 PAR
C	Outside	Euro 215mm
B	Outside	Silhouette 2K
A	Outside	Various PAR 64
1	Outside	Strand 2K



Note: The Chroma-Q Universal should always be used with the safety wire provided.

2.6 Troubleshooting

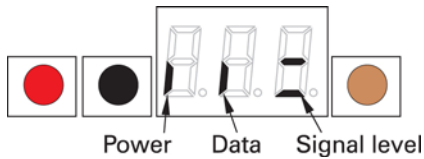

The first vertical bar indicates that there is power (24VDC).
 The second vertical bar indicates that there is data (DMX).
 The horizontal bars indicate the data (DMX) signal level.
Note: The signal level changes during normal operation of the unit. 1st bar = 25%, 2nd bar = 50% and 3rd bar = 75%

Symptom	Possible Cause	Solution
Unit does not respond to DMX control, but DMX indicator is on.	Unit set to a wrong or different DMX address.	Check DMX address settings.
Unit does not respond to DMX, DMX indicator is off.	Bad cable. No DMX present at Splitter/PSU unit.	Check cable and DMX run from console.
Units run at different speeds.	Scroller speed settings may be different. Cable lengths are too long. No cable return line.	Check all scroller speed settings. Check the cable length and configuration. Ensure there is a cable return line in the system.
Units have dim display indicators and run slowly	Overloading of colour changer chain or cable runs too long. PSU overloaded.	Check voltage levels on last unit. Should not be below 20VDC.
DMX display indicator is off on one unit.	Bad cable or blown transceiver IC in the scroller.	Check cable or send unit for repair.
Display indicators appear ok but gel string does not move.	Mechanical (or electrical) failure in the unit.	Turn unit on and off. Return unit for repair.
Gel burns too quickly.	Fans have failed or are too slow. Poorly optimised lamp focus in fixture. IR filter medium not fitted.	Check fans are operating. Optimise lamp focus. Replace gel strings & install IR filter.

Note: A high percentage of problems are a direct result of poor cable, corrupt DMX control signals and lack of suitable signal termination.

2.7 Technical overview

The colour transport system employs an opto-electronic system for accurate positioning of the gel. When the unit initially receives power it will go through a calibration sequence. The purpose of the initial calibration sequence during power up is to determine the total length of the gel string and therefore the position of the different gels.

Note: Over time the gel string may warp slightly. This may alter the positions of the gels relative to their pre-programmed DMX values and therefore some 'fine-tuning' may be required.

The motors have an optical encoder feedback system. The purpose of this is to convert motor revolutions in to electronic pulses, and also to determine which direction the motor is turning.

The electronic cards consist of three key components: L298 motor driver, 75176 Transceiver and a processor. The L298 is a true digital device receiving two PWM signals to operate speed and direction. The 75176 transceiver operates in the receive configuration to convert serial protocol to a TTL level. All data relevant to the operation of the unit is stored onboard in 'flash' memory.

The majority of electronics problems are usually created by external factors such as shorted cables, etc. The 75176 transceivers are susceptible to damage if 24VDC is present on the DMX signal lines.

Routine maintenance can prevent most mechanically based problems. The motor mounting plate can be adjusted to control tension on the belt. Excessive belt tension is often the cause of noise and poor performance. Conversely, loose motor belts can cause accuracy problems.

Troubleshooting is a process of elimination. First, rule out the other field factors (i.e. faulty cables, power sources). If an electronics problem is suspected try replacing the electronics card first. If accuracy problems should occur and mechanical problems have been ruled out, replace optical sensors. For technical advice and/ or parts, please contact your selling dealer or the offices listed in this manual.

2.8 Technical specifications

Dimensions:	345mm (w) × 359mm (h) × 80mm (d) 13.6" × 14.1" × 3.1" inc. mounting brackets
Weight:	2.5kg/5.5 lb inc. gel string & mounting brackets
Rear aperture:	203mm/8"
Front aperture:	260mm/10.25"
Colour media:	Pro Color HT+, Rosco Supergel and GAMcolor recommended
Gel capacity:	2-24 gels
Cooling:	2 fan design
Cooling Speed:	Multiple speeds
DMX protocol:	ANSI E1.11 USITT DMX 512-A
DMX addressing:	Digitally via 3 push buttons and LED display
Working Voltage:	24 VDC (+/- 10%)
Power consumption:	1.5PU (see note below)
Connectors:	XLR-4 (male) in and XLR-4 (female) through
Body material:	Aluminium
Body color:	Black powder coat (other colours available, P.O.A.)
Mounting plate:	Universal mounting system fits 160-275mm / 6¼"-10¾" fixtures
Approvals:	EN55103-1 and 2, IEC 60950, FCC Part 15 and ICES-003 Class A

Note: To simplify the choice of power supply we use the "PU" (Power Unit) to calculate the load requirements of the Chroma-Q system. For example a PS-08 will supply up to 8 PU's, so you can plug-in 5 Chroma-Q Universals (5 x 1.5PU = 7.5PU) into a PS-08.



3. Drawings

3.1 Outside dimensions

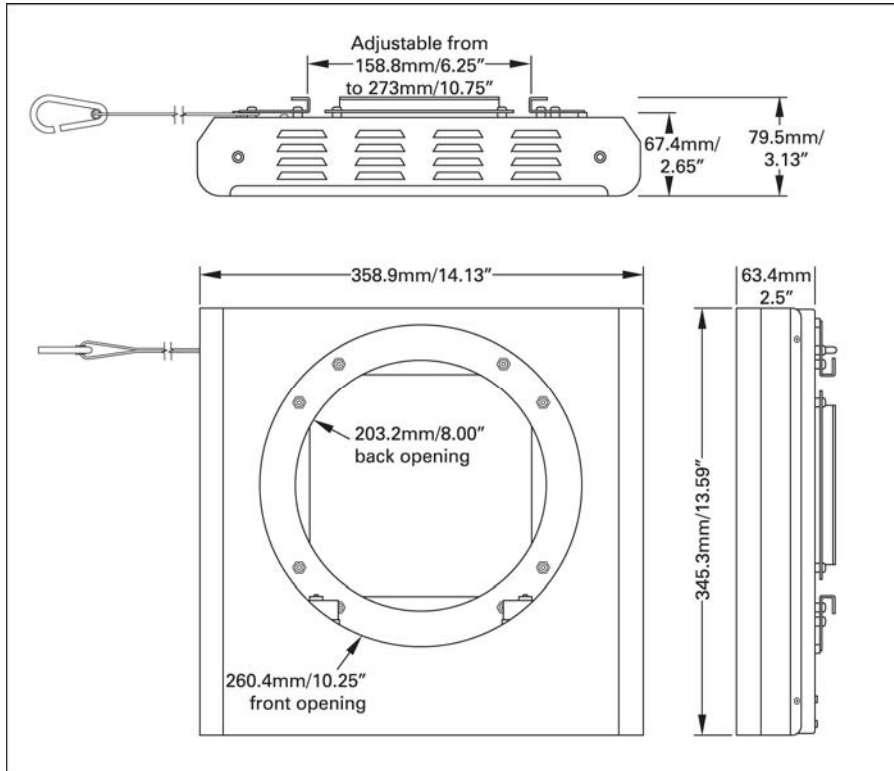

3.2 Gel dimensions

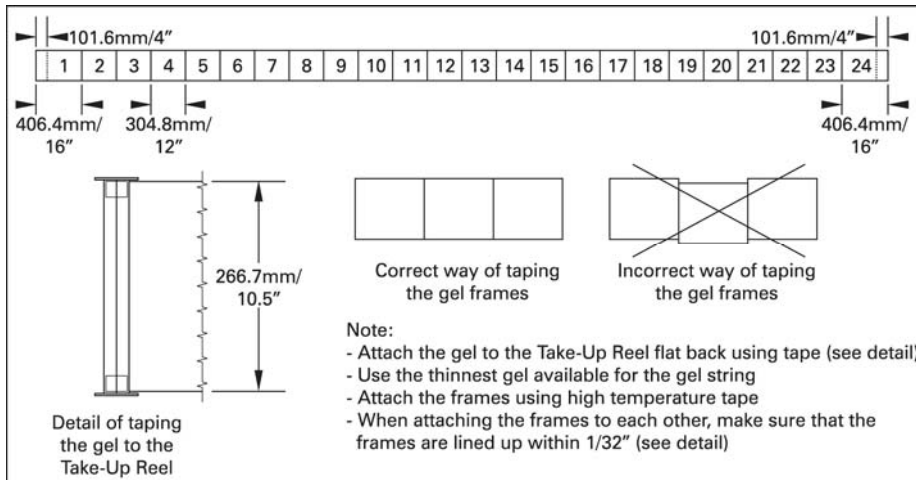

3.3 Examples of mounting bracket positions

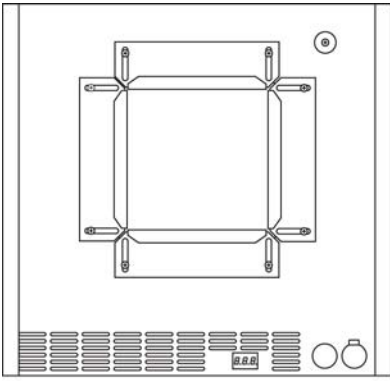

Mounting Brackets set for 8 1/4"
eg ETC Source 4

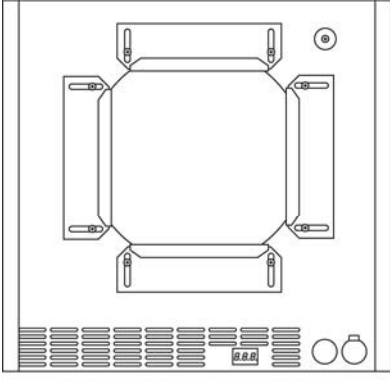

Mounting Brackets set for 10 1/8"
eg ETC Source 4 PAR

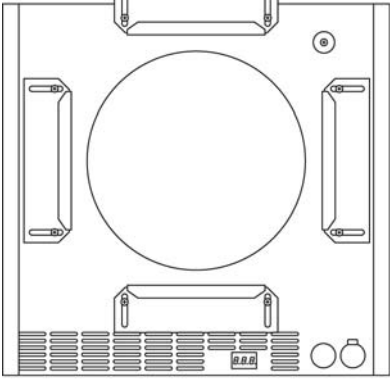

Mounting Brackets set for 10 1/4"
eg Parcan